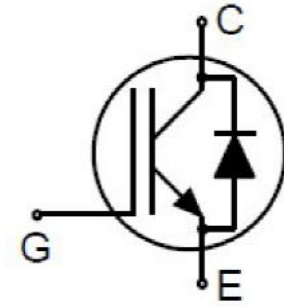


### Features

- High breakdown voltage to 1200V for improved reliability
- Trench-stop technology offering:
  - High speed switching
  - High ruggedness, temperature stable behavior
  - Low switching losses
  - Low  $V_{CE(SAT)}$
  - Easy parallel switching capability due to positive temperature coefficient in  $V_{CE(SAT)}$
- Converter with high switching frequency
- RoHS compliant with Halogen-free

HF

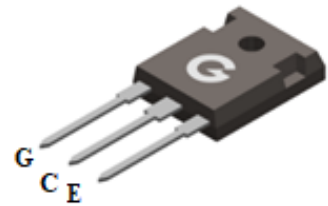


### Applications

- Uninterruptible power supplies
- Solar inverter

### Mechanical Data

- Case: TO-247
- Molding Compound: UL Flammability Classification Rating 94V-0
- Terminals: Matte tin-plated leads; solderability-per MIL-STD-202, Method 208



TO-247

### Ordering Information

Part Number	Package	Shipping Quantity	Marking Code
GKU40N120DH5	TO-247	30 pcs / Tube	KU40N120DH5

### Maximum Ratings (@ $T_C = 25^\circ\text{C}$ unless otherwise specified)

Parameter	Symbol	Value	Unit
Collector-to-Emitter Voltage	$V_{CES}$	1200	V
Gate-Emitter Voltage	$V_{GES}$	$\pm 20$	V
DC Collector Current ( $T_C = 25^\circ\text{C}$ , limited by maximum $T_J$ )	$I_C$	80	A
DC Collector Current ( $T_C = 100^\circ\text{C}$ , limited by maximum $T_J$ )		40	A
Diode Continuous Forward Current ( $T_C = 25^\circ\text{C}$ , limited by maximum $T_J$ )	$I_F$	40	A
Diode Continuous Forward Current ( $T_C = 100^\circ\text{C}$ , limited by maximum $T_J$ )		20	A
Pulsed Collector Current (Pulse width limited by maximum $T_J$ , $V_{GE} = 15\text{V}$ )	$I_{CM}$	160	A
Pulsed Source-Drain Current (Pulse width limited by maximum $T_J$ )	$I_{FM}$	80	A
Soldering Temperature, Wave Soldering 1.6mm (0.063in.) from case for 10s	$T_{sold}$	260	$^\circ\text{C}$
Power Dissipation ( $T_C = 25^\circ\text{C}$ )	$P_D$	375	W
Operating Junction Temperature Range	$T_J$	-55 ~ +175	$^\circ\text{C}$
Storage Temperature Range	$T_{STG}$	-55 ~ +150	$^\circ\text{C}$

### Thermal Characteristics

Parameter	Symbol	Min.	Typ.	Max.	Unit
Thermal Resistance Junction-to-Case, IGBT	R <sub>θJC</sub>	-	-	0.4	°C/W
Thermal Resistance Junction-to-Case, Diode		-	-	1	°C/W
Thermal Resistance Junction-to-Air	R <sub>θJA</sub>	-	-	40	°C/W

### Electrical Characteristics of the IGBT (@ T<sub>J</sub> = 25°C unless otherwise specified)

Symbol	Parameter	Test Condition	Min.	Typ.	Max.	Unit
<b>Static Characteristics</b>						
V <sub>(BR)CES</sub>	Collector-Emitter Breakdown Voltage	V <sub>GE</sub> = 0V, I <sub>C</sub> = 250μA	1200	-	-	V
I <sub>CES</sub>	Collector-Emitter Leakage Current	V <sub>CE</sub> = 1200V, V <sub>GE</sub> = 0V, T <sub>J</sub> = 25°C	-	-	250	μA
		V <sub>CE</sub> = 1200V, V <sub>GE</sub> = 0V, T <sub>J</sub> = 175°C	-	-	5	mA
I <sub>GES</sub>	Gate to Emitter Leakage Current	V <sub>GE</sub> = ±20V, V <sub>CE</sub> = 0V	-	-	±400	nA
V <sub>CE(sat)</sub>	Collector-Emitter Saturation Voltage	V <sub>GE</sub> = 15V, I <sub>C</sub> = 40A, T <sub>J</sub> = 25°C	-	1.85	2.4	V
		V <sub>GE</sub> = 15V, I <sub>C</sub> = 40A, T <sub>J</sub> = 175°C	-	2.35	-	V
V <sub>GE(th)</sub>	Gate Threshold Voltage	V <sub>CE</sub> = V <sub>GE</sub> , I <sub>C</sub> = 250μA	4.2	-	5.8	V
<b>Dynamic Characteristics</b>						
g <sub>fs</sub>	Transconductance	V <sub>CE</sub> = 20V, I <sub>C</sub> = 40A	-	32	-	S
Q <sub>G</sub>	Total Gate-Charge	V <sub>CC</sub> = 960V, V <sub>GE</sub> = 15V, I <sub>C</sub> = 40A	-	239	-	nC
C <sub>ies</sub>	Input Capacitance	V <sub>CE</sub> = 25V	-	6830	-	pF
C <sub>oes</sub>	Output Capacitance	V <sub>GE</sub> = 0V	-	142	-	
C <sub>res</sub>	Reverse Transfer Capacitance	f = 1MHz	-	29	-	
<b>Switching Characteristics</b>						
t <sub>d(on)</sub>	Turn-on Delay Time	V <sub>CE</sub> = 600V V <sub>GE</sub> = 15V I <sub>C</sub> = 40A R <sub>G</sub> = 10Ω T <sub>J</sub> = 25°C	-	39	-	ns
t <sub>r</sub>	Turn-on Rise Time		-	91	-	
t <sub>d(off)</sub>	Turn-Off Delay Time		-	258	-	
t <sub>f</sub>	Turn-Off Fall Time		-	60	-	
E <sub>on</sub>	Turn-On Switching Loss	T <sub>J</sub> = 25°C	-	3.22	-	mJ
E <sub>off</sub>	Turn-Off Switching Loss		-	0.99	-	

### Electrical Characteristics of the Diode (@ T<sub>J</sub> = 25°C unless otherwise specified)

Symbol	Parameter	Test Condition	Min.	Typ.	Max.	Unit
<b>Dynamic Characteristics</b>						
V <sub>FM</sub>	Diode Forward Voltage	I <sub>F</sub> = 15A, V <sub>GE</sub> = 0V	-	2.5	-	V
t <sub>rr</sub>	Reverse recovery time	V <sub>R</sub> = 600V, I <sub>F</sub> = 40A, di/dt = 700A/μs	-	250	-	ns
Q <sub>rr</sub>	Reverse recovery charge		-	1000	-	nC
I <sub>rrm</sub>	Peak Reverse Recovery Current		-	11	-	A

### Ratings and Characteristics Curves (@ $T_A = 25^\circ\text{C}$ unless otherwise specified)

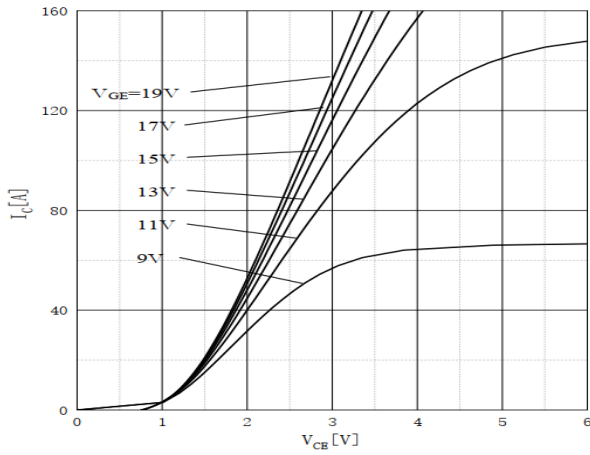


Fig 1 Typical Output Characteristics ( $T_j = 25^\circ\text{C}$ )

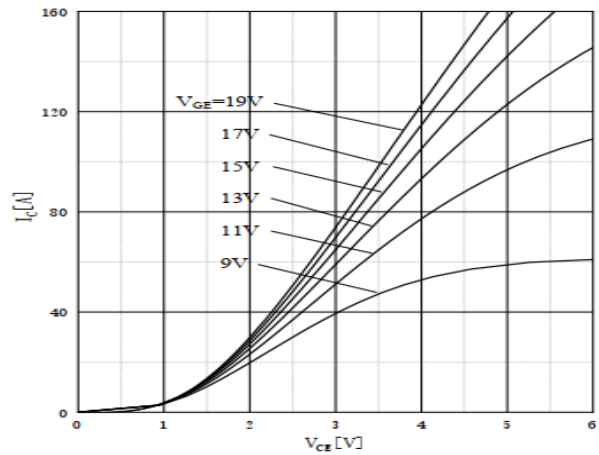


Fig 2 Saturation Voltage Characteristics ( $T_j = 175^\circ\text{C}$ )

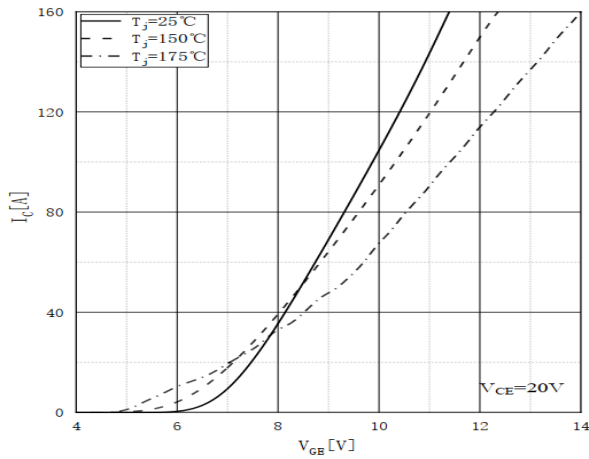


Fig 3 Transfer Characteristics

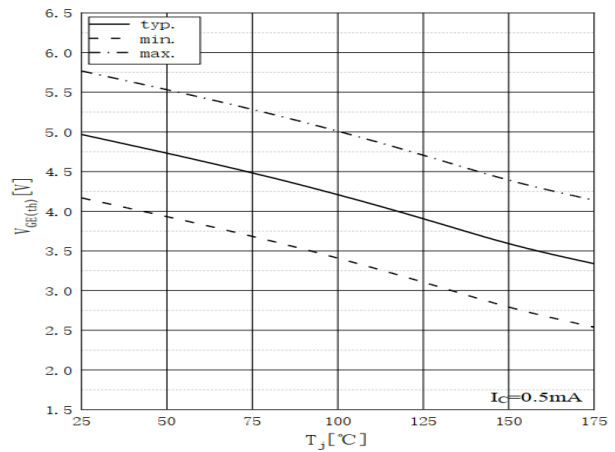


Fig 4  $V_{GE(th)}$  vs. Junction Temperature

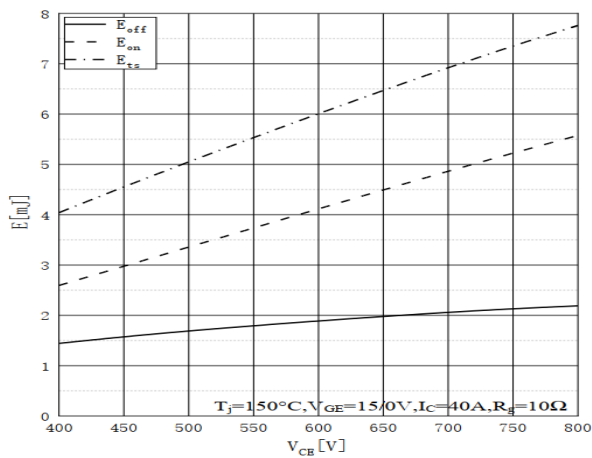


Fig 5 Switching Loss vs. Collector-Emitter Voltage

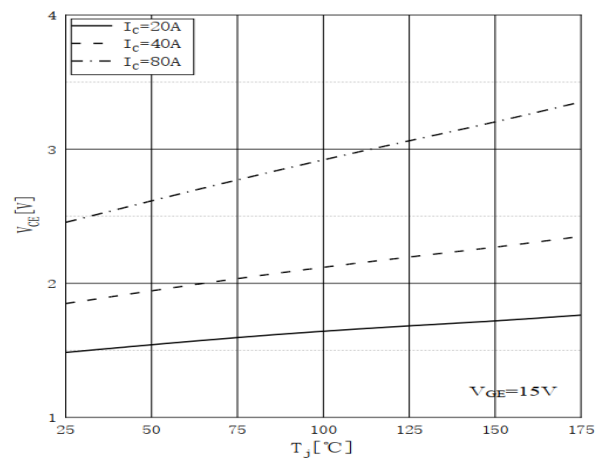
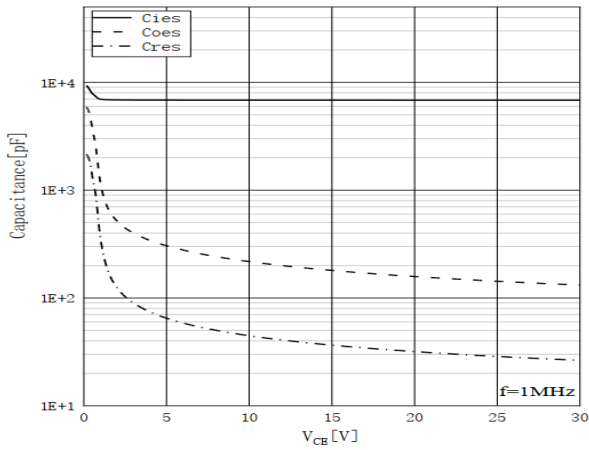
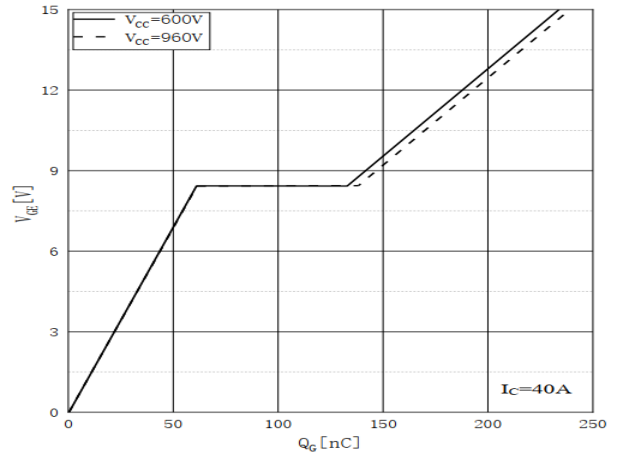


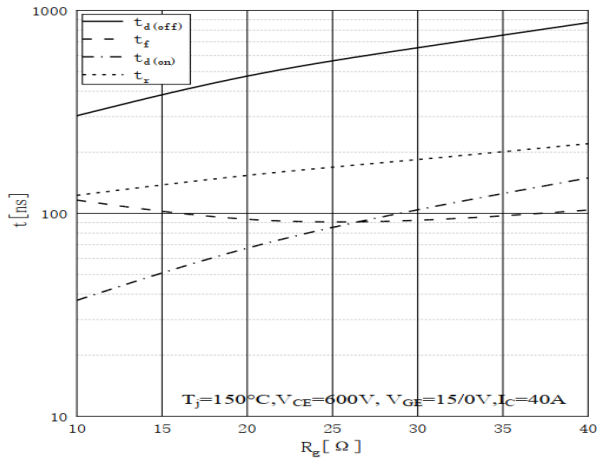
Fig 6 Collector-Emitter Saturation Voltage vs. Junction Temperature



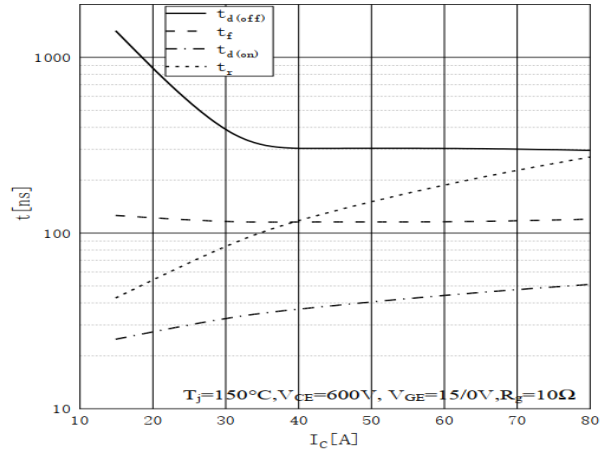
**Fig 7 Capacitance Characteristics**



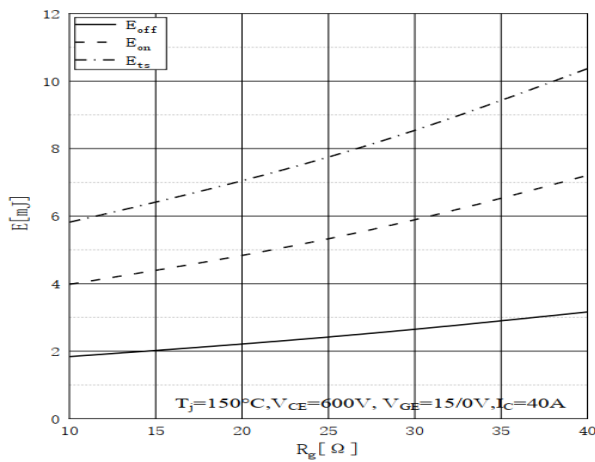
**Fig 8 Gate-Charge Characteristics**



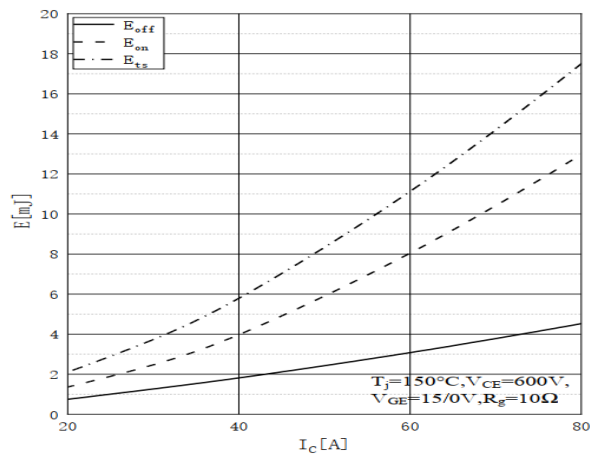
**Fig 9 Switching Times vs. Gate Resistor**



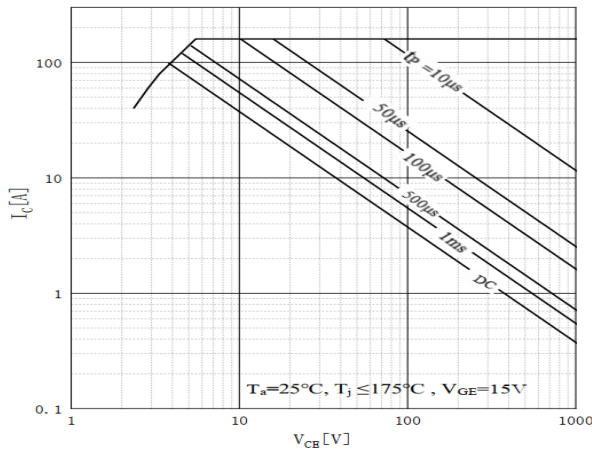
**Fig 10 Switching Times vs. Collector Current**



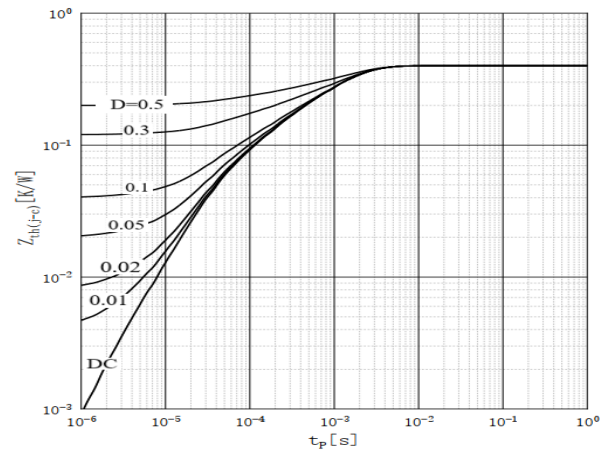
**Fig 11 Switching Loss vs. Gate Resistor**



**Fig 12 Switching Loss vs. Collector Current**

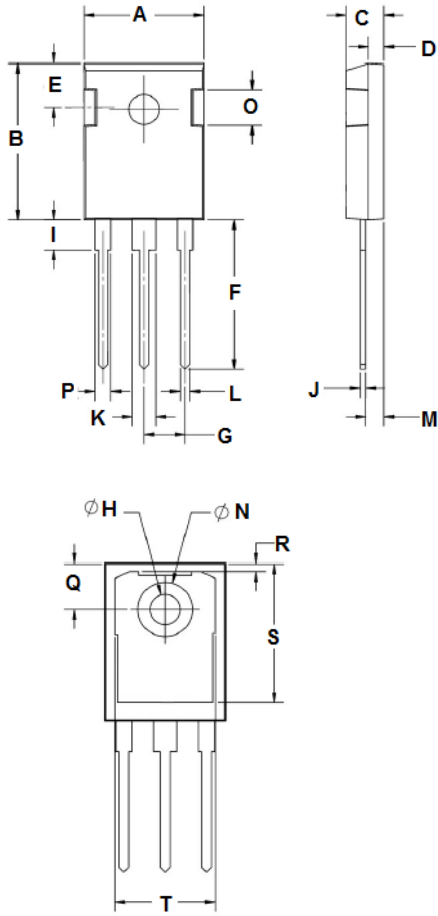


**Fig 13 SOA characteristics**



**Fig 14 Maximum transient thermal impedance**

**Package Outline Dimensions** (Unit: mm)



TO-247		
Dimension	Min.	Max.
A	15.50	16.10
B	20.70	21.30
C	4.70	5.30
D	1.80	2.20
E	5.20	5.80
F	19.70	20.30
G	5.20	5.60
H	3.30	3.70
I	3.90	4.30
J	0.50	0.70
K	2.80	3.20
L	1.00	1.40
M	2.20	2.60
N	7.00	7.20
O	4.90	5.30
P	1.80	2.20
Q	5.70	5.90
R	0.80	1.20
S	17.00	17.80
T	13.60	14.20