



## Features

- High isolation 5000 VRMS
- Patented coplanar structure DMC-Isolator®
- OFF-state output terminal voltage: 400 V (min)
- Operating temperature range - 40 °C to 85 °C
- External Creepage  $\geq 7.0\text{mm}$
- Distance Through Isolation  $\geq 0.4\text{mm}$
- RoHS compliance
- REACH compliance
- Halogen free
- Regulatory Approvals
  - UL - UL1577 (E364000)
  - VDE - EN60747-5-5(40039590)
  - CQC – GB4943.1, GB8898(14001104781)
  - IEC62368 (FI/41119)

## Description

The CTR214-4L (1-form-A) consists of two MOSFET and one photovoltaic chip optically coupled to an Infrared-emitting diode in a 4-lead DIP package different lead forming options.

## Applications

- Battery Management System (BMS)
- Security Systems
- Smart Meters
- Mechanical relay replacements
- General telecom switching
- Industrial controls
- Automatic measurement equipment

## Package Outline

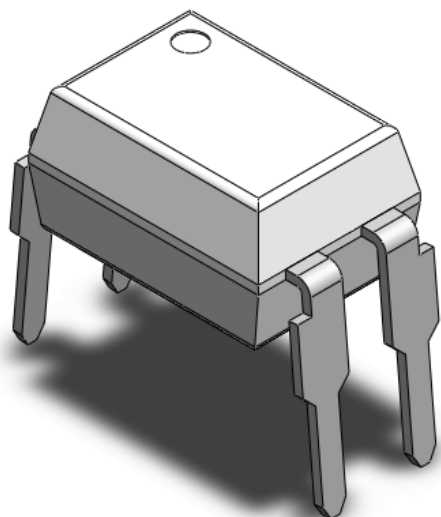

## Schematic

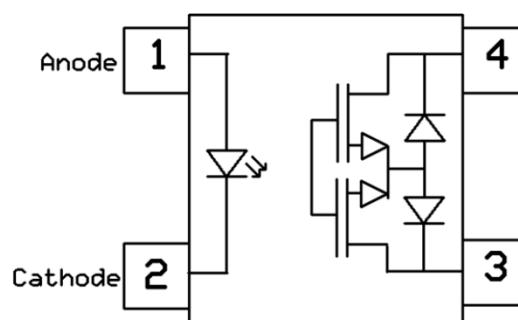

Note: Different bending options available. See package dimension.



### Absolute Maximum Ratings $T_A = 25^{\circ}\text{C}$ , unless otherwise specified

Stresses in excess of the absolute maximum ratings can cause permanent damage to the device. Functional operation of the device is not implied at these or any other conditions in excess of those given in the operational sections of this document. In addition, extended exposure to stresses above the recommended operating conditions may affect device reliability. The absolute maximum ratings are stress ratings only.

Symbol	Parameters	Ratings	Units	Notes
$V_{ISO}$	Isolation voltage	5000	Vrms	AC,60 s
$T_{OPR}$	Operating temperature	-40 ~+85	$^{\circ}\text{C}$	
$T_{STG}$	Storage temperature	-40 ~+100	$^{\circ}\text{C}$	
$T_{SOL}$	Soldering temperature	260	$^{\circ}\text{C}$	1
<b>Emitter</b>				
$I_F$	LED forward current	25	mA	
$I_{FP}$	LED forward current (pulsed) ( $\leq 1\mu\text{s P.W}, 300\text{pps}$ )	100	mA	
$V_R$	LED reverse voltage	6	V	
$P_{in}$	Power dissipation	40	mW	
$T_j$	Junction Temperature	125	$^{\circ}\text{C}$	
<b>Detector</b>				
$V_{OFF}$	OFF-state output terminal Voltage	400	V	
$I_{ON}$	ON-state Current	CTR214	80	mA
		CTR214B	140	mA
$P_o$	Output Power dissipation	CTR214	320	mW
		CTR214B	392	mW
$T_j$	Junction Temperature	125	$^{\circ}\text{C}$	

#### Notes

- For reflow profile 10 second peak.

### Recommended Operating Conditions

Symbol	Parameters	Min	Typ	Max	Units
$V_{DD}$	Supply Voltage	-	-	320	V
$I_{FT}$	Trigger LED Current	5	10	25	mA
$T_{OPR}$	Operating temperature	-40	-	60	$^{\circ}\text{C}$



**Electrical Characteristics**  $T_A = 25^{\circ}\text{C}$ , unless otherwise specified

**Emitter Characteristics**

Symbol	Parameters	Test Conditions	Min	Typ	Max	Units	Notes
$V_F$	Forward voltage	$I_F = 10\text{mA}$	-	1.4	1.6	V	
$I_R$	Reverse Current	$V_R = 6\text{V}$	-	-	5	$\mu\text{A}$	

**Detector Characteristics**

Symbol	Parameters	Test Conditions	Min	Typ	Max	Units	Notes
$I_{OFF}$	OFF-state Current	$V_{OFF} = 400\text{V}$	-	0.1	1	$\mu\text{A}$	
$C_{OFF}$	Output Capacitance	$V_O = 0\text{V}$ , $f = 1\text{MHz}$	-	30	-	pF	

**Transfer Characteristics**

Symbol	Parameters	Test Conditions	Min	Typ	Max	Units	Notes	
$I_{FT}$	Trigger LED Current	$I_{ON} = \text{Max}$	-	1.5	5	mA		
$R_{ON}$	ON-state resistance	CTR214-4L	$I_{ON} = \text{Max}$ , $I_F = 5\text{mA}$ , $t < 1\text{s}$	-	-	50	$\Omega$	
		CTR214B-4L	$I_{ON} = \text{Max}$ , $I_F = 5\text{mA}$ , $t < 1\text{s}$	-	15	20	$\Omega$	

**Switching Characteristics**

Symbol	Parameters	Test Conditions	Min	Typ	Max	Units	Notes
$t_{ON}$	Turn-on Time	$R_L = 200\Omega$ , $V_{DD} = 20\text{V}$ , $I_F = 5\text{mA}$	-	0.4	1	ms	
$t_{OFF}$	Turn-off Time		-	0.4	1	ms	



**Typical Characteristic Curves**  $T_A = 25^\circ\text{C}$ , unless otherwise specified

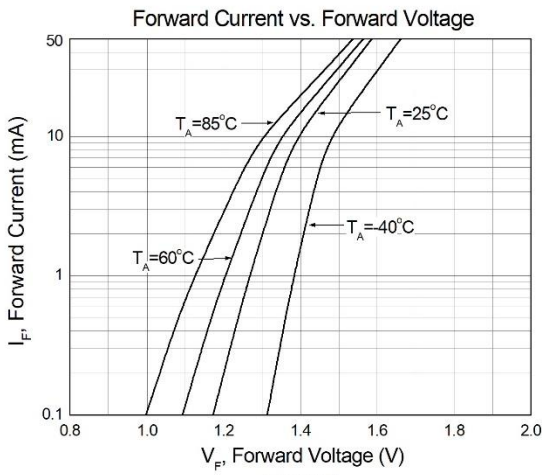

Figure 1

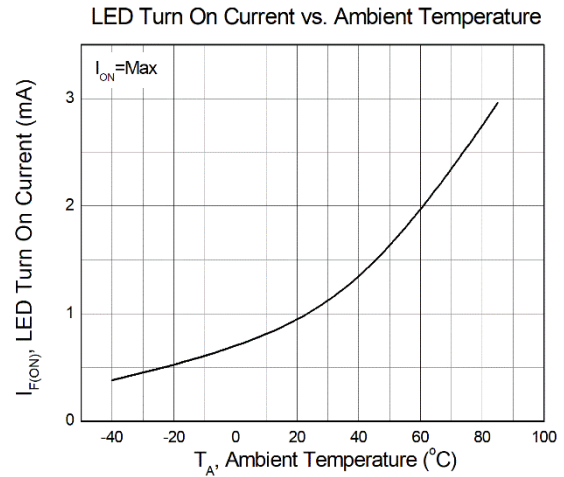

Figure 2

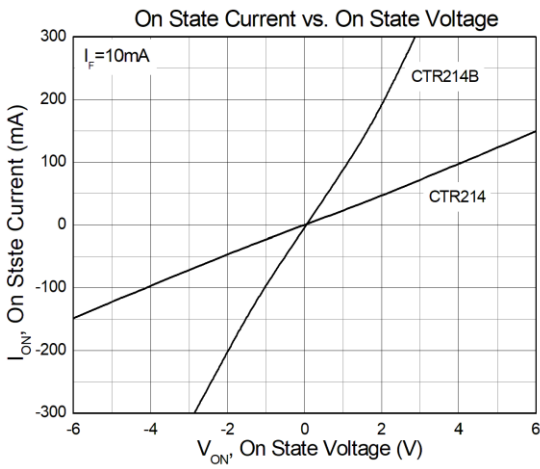

Figure 3

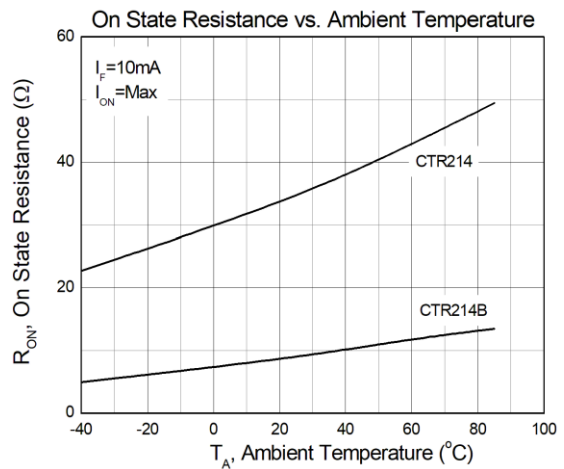

Figure 4

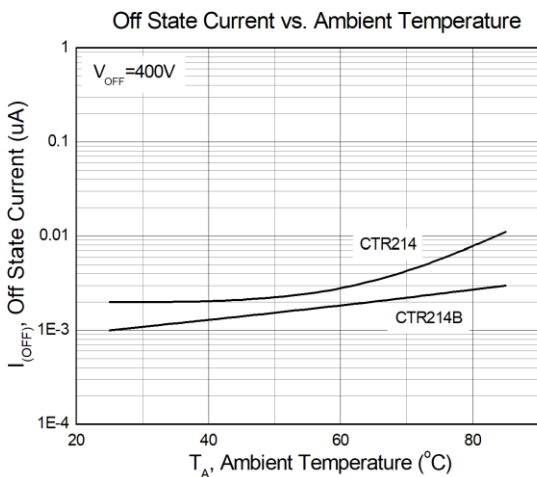

Figure 5

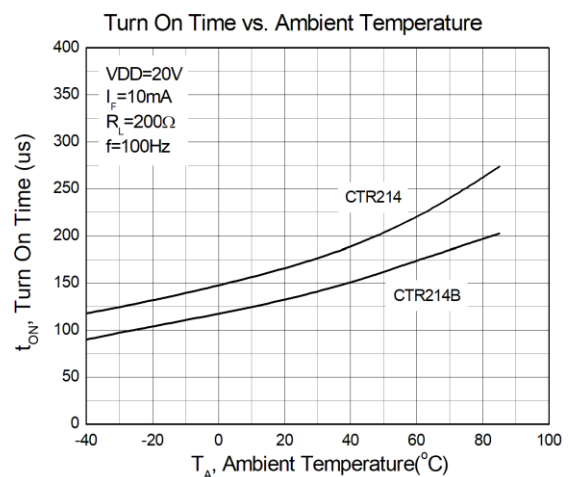

Figure 6

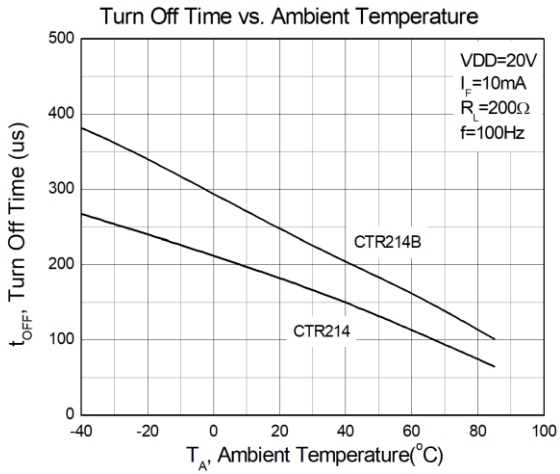

Figure 7

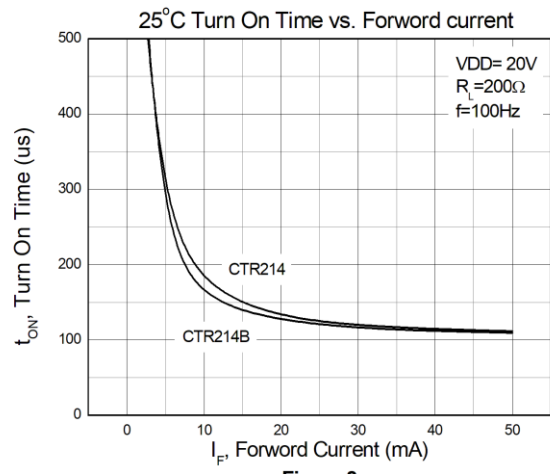

Figure 8

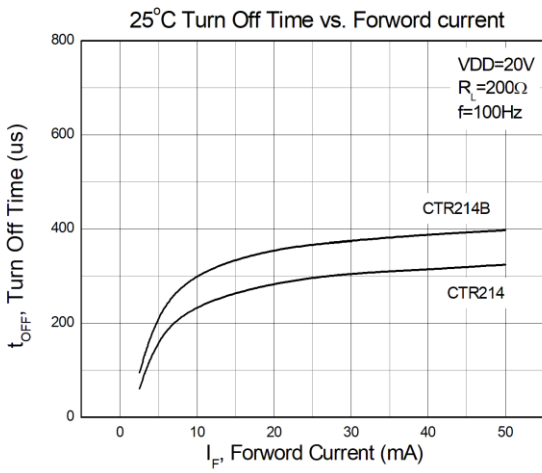
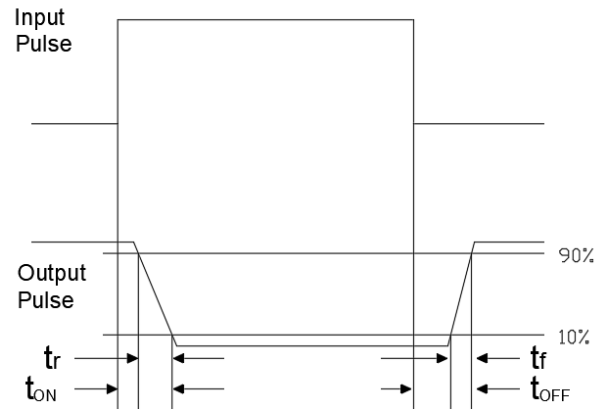
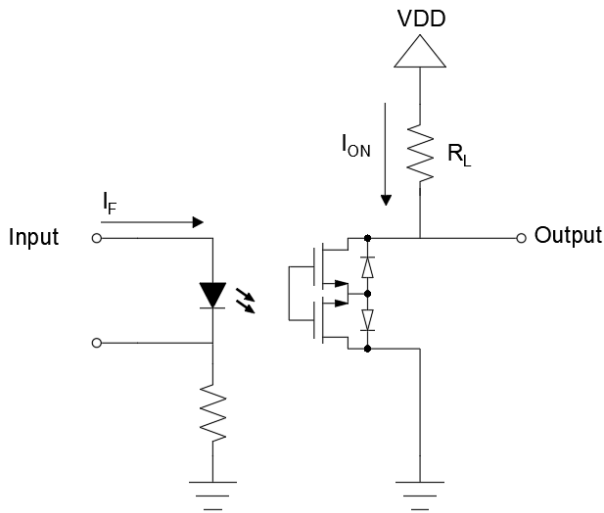

Figure 9



## Test Circuit



## Switching Time Test Circuits



**Package Dimension** *Dimensions in mm unless otherwise stated*

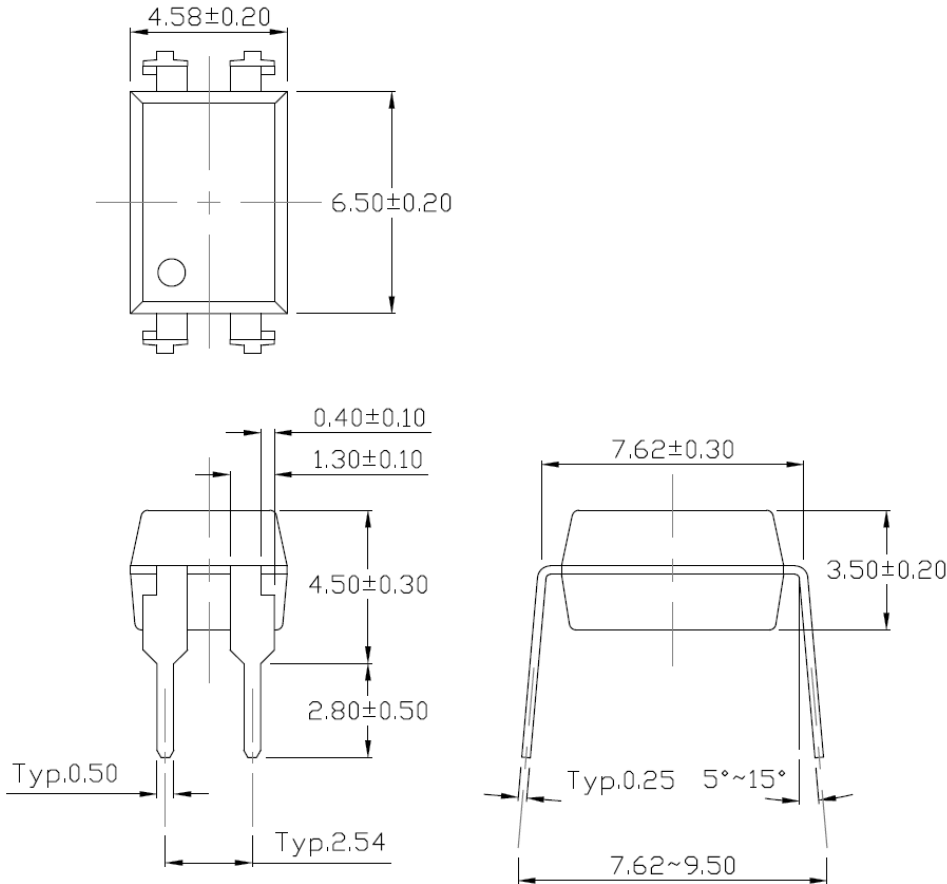

**Forming Option** *Dimensions in mm unless otherwise stated*

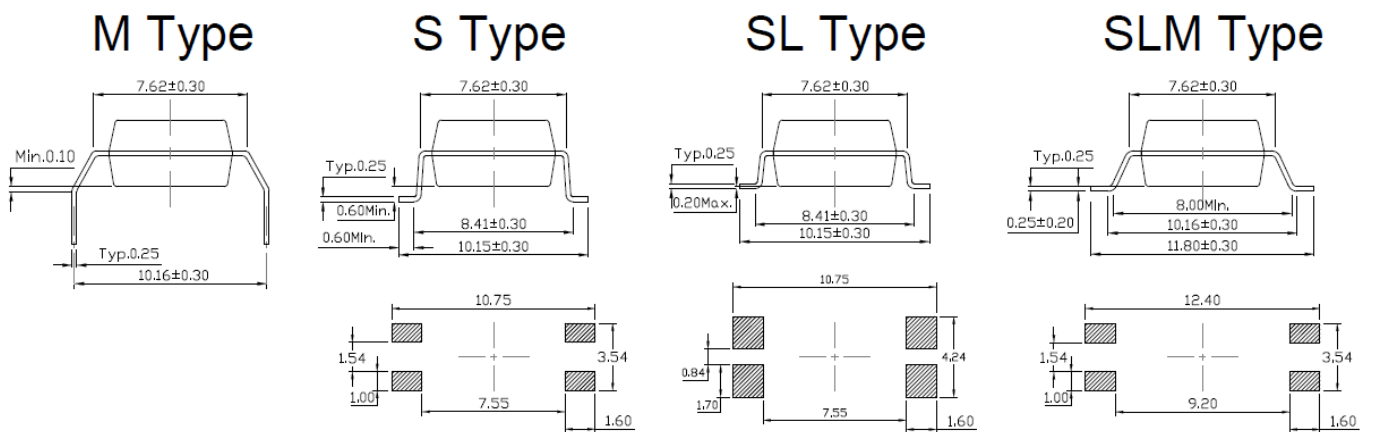



### Marking Information



#### Note:

- CT : Denotes “CT Micro”
- R214 : Part Number
- X : Option (Blank or B)
- V : VDE Safety Mark Option (Blank or V)
- Y : One Digit Year Code
- WW : Two Digit Work Week
- K : Manufacturing Code

### Ordering Information

#### CTR214X(V)(Y)(Z)-4L

- CT = Denotes “CT Micro”
- R214 = Part Number
- X = Option (Blank or B)
- V = VDE Safety Mark Option (Blank or V)
- Y = Lead Form Option (Blank, S, SL, M or SLM)
- Z = Tape and Reel Option (Blank, T1 or T2)

<b>Option</b>	<b>Description</b>	<b>Quantity</b>
None	Standard 4 Pin DIP	100 Units/Tube
M	Gullwing (400mil) Lead Forming	100 Units/Tube
S(T1)	Surface Mount Lead Forming – With Option 1 Taping	1500 Units/Reel
S(T2)	Surface Mount Lead Forming – With Option 2 Taping	1500 Units/Reel
SL(T1)	Surface Mount (Low Profile) Lead Forming– With Option 1 Taping	1500 Units/Reel
SL(T2)	Surface Mount (Low Profile) Lead Forming – With Option 2 Taping	1500 Units/Reel
SLM(T1)	Surface Mount (Gullwing) Lead Forming– With Option 1 Taping	1500 Units/Reel
SLM(T2)	Surface Mount (Gullwing) Lead Forming – With Option 2 Taping	1500 Units/Reel



www.ct-micro.com

# CTR214-4L 4-Pin DMC-Isolator® Opto MOS Relays

## Carrier Specifications *Dimensions in mm unless otherwise stated*

### Tube Option Standard DIP

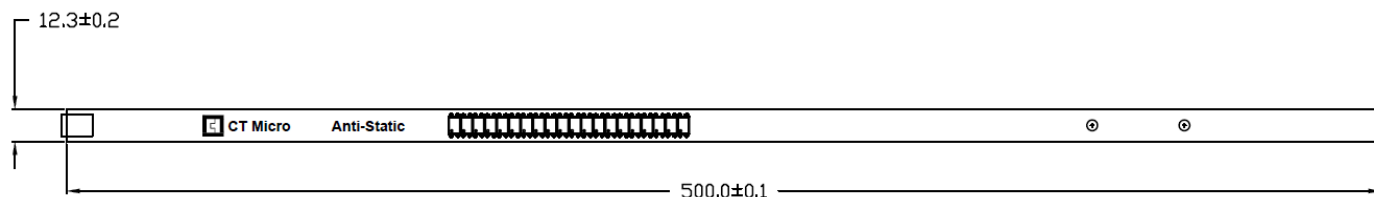

### Tube Option M Type

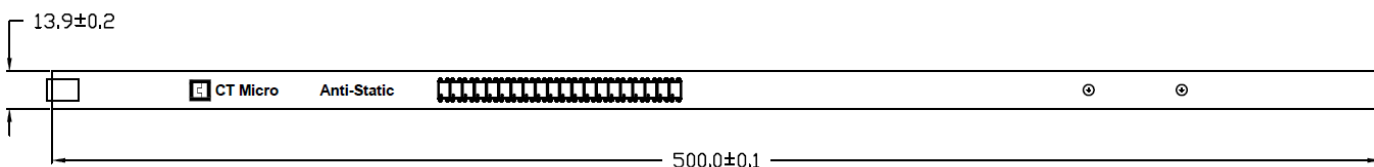

## Reel Dimension *Dimensions in mm unless otherwise stated*

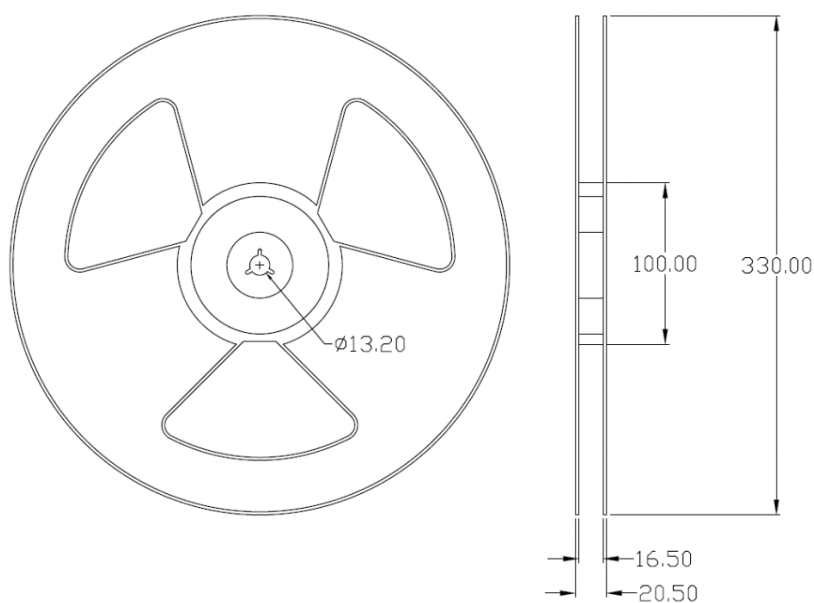



**Carrier Tape Specifications** *Dimensions in mm unless otherwise stated*

**Option S(T1) & SL(T1)**

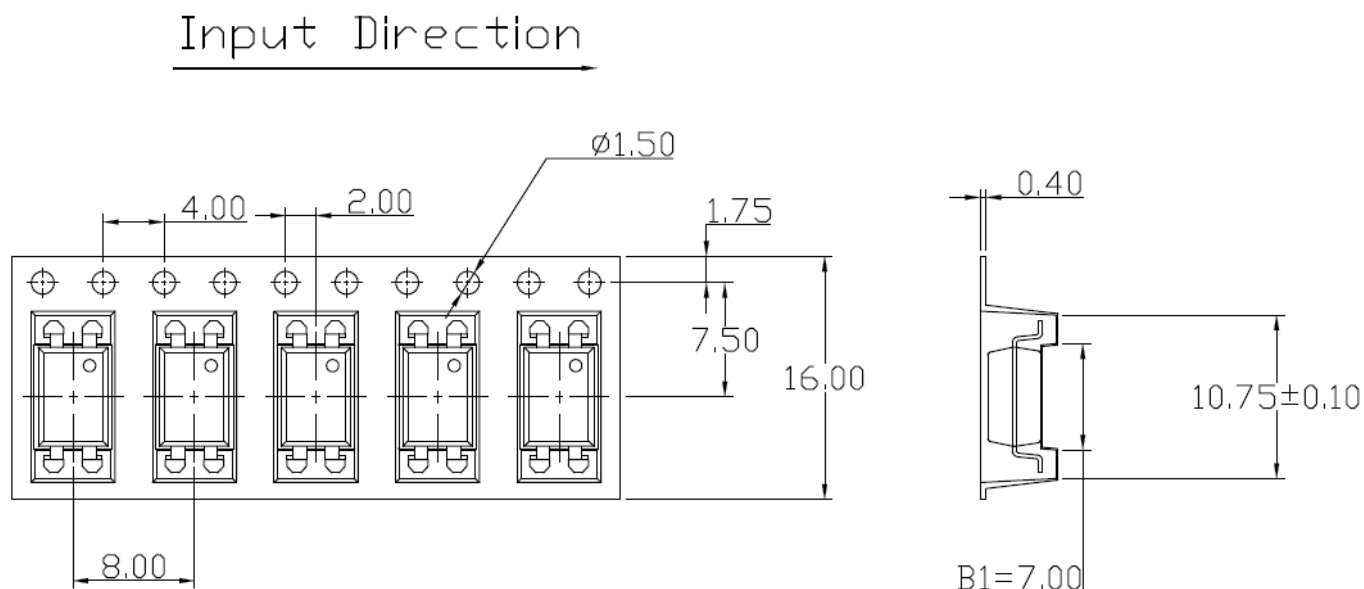

**Option S(T2) & SL(T2)**

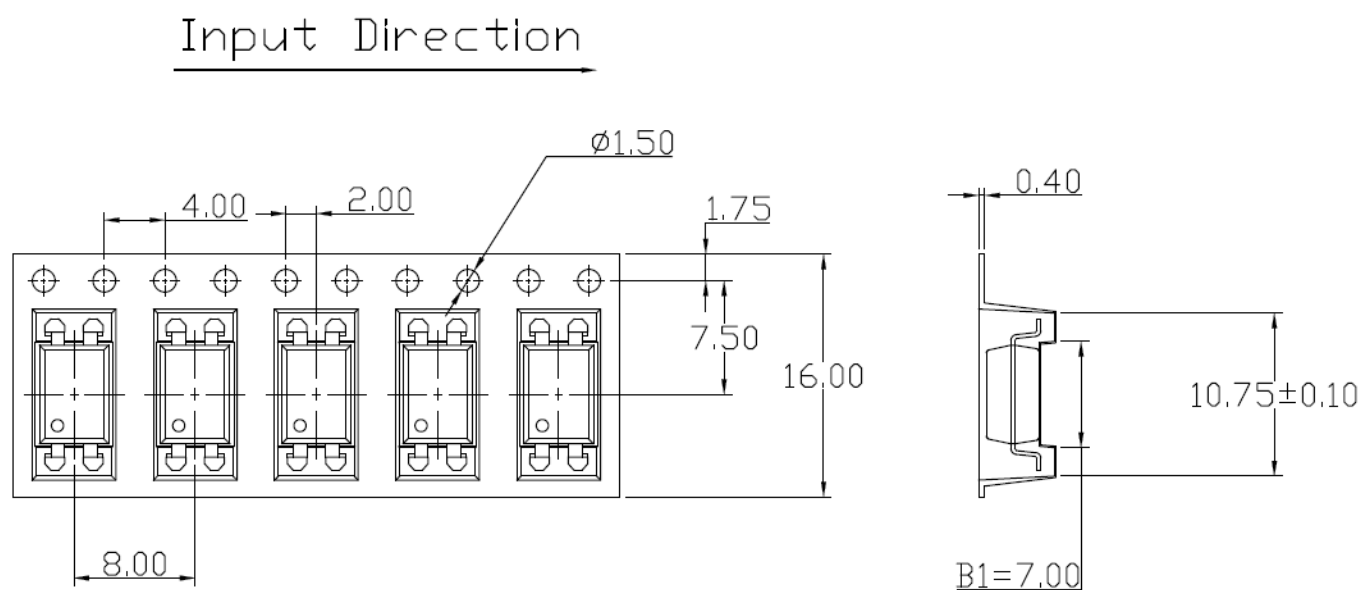



**Option SLM(T1)**

Input Direction  
→

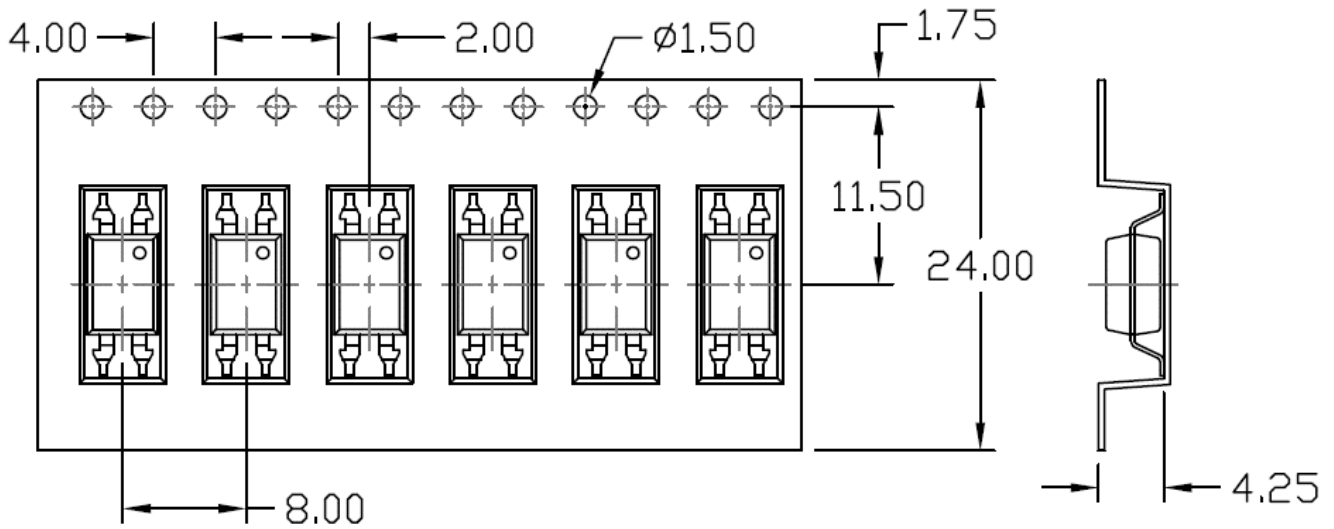

**Option SLM(T2)**

Input Direction  
→

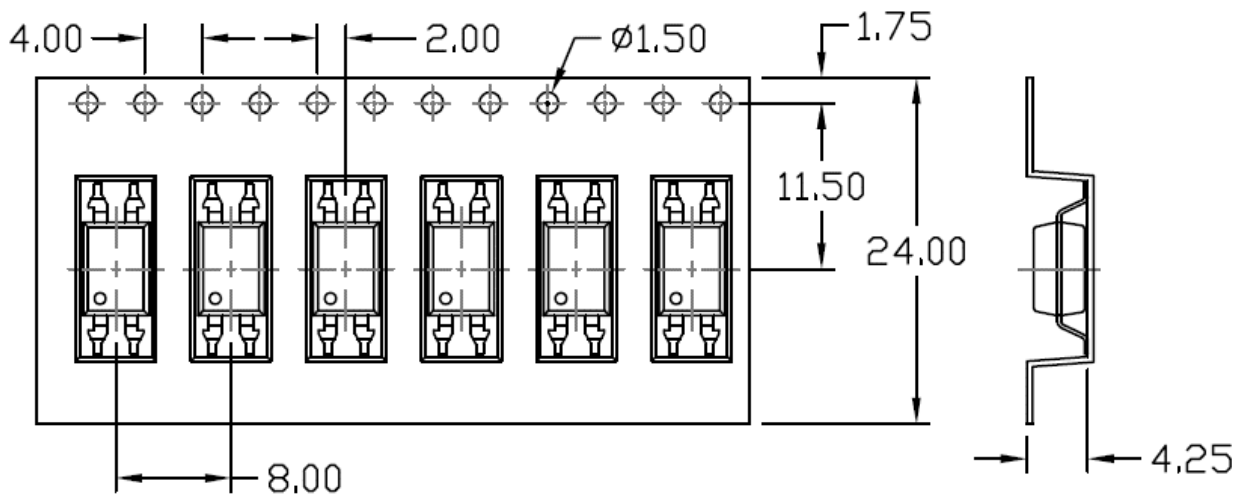



### **Solderability Specification (follow the JEDEC standard JESD22-B102)**

Reflow Soldering: Immersed surface, other than the end of pin as cut-surface, must be covered by solder.

Solder-Bath: More than 95% of the electrode must be covered with solder.

### **Wave Soldering (follow the JEDEC standard JESD22-A111)**

One time soldering is recommended within the condition of temperature.

Temperature:  $260 \pm 0/-5^{\circ}\text{C}$ .

Time: 10 sec.

Preheat temperature: 25 to  $140^{\circ}\text{C}$ .

Preheat time: 30 to 80 sec.

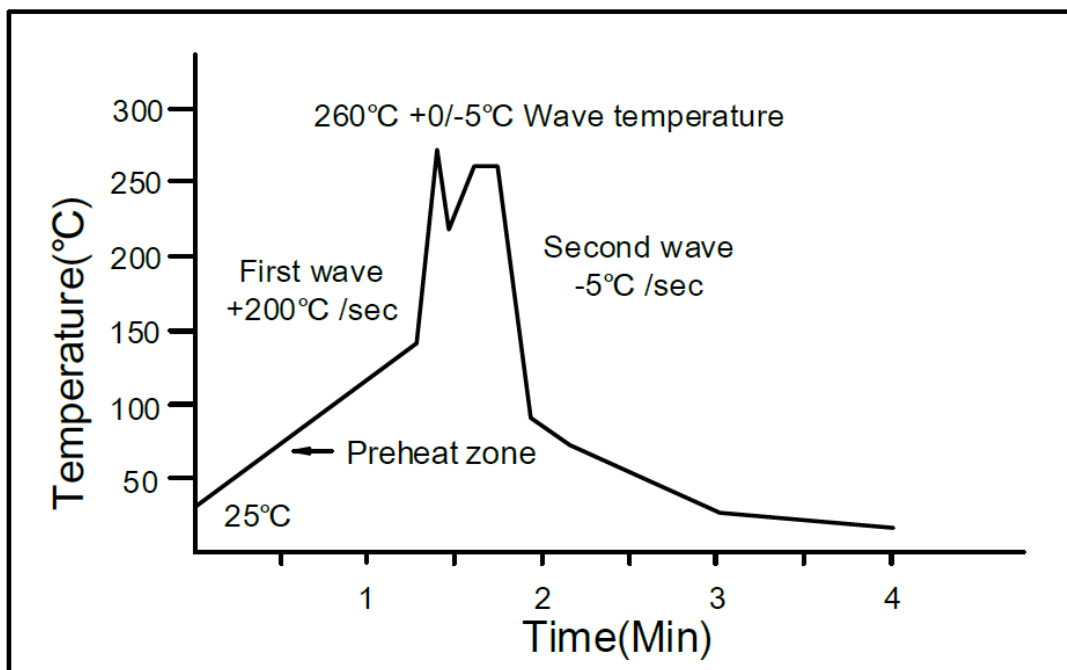

### **Iron Soldering (follow the standard MIL-STD 202G, Method 210F)**

Allow single lead soldering in every single process.

One time soldering is recommended.

Temperature:  $350 \pm 10^{\circ}\text{C}$

Time: 5 sec max.



**Reflow Profile (Follow the JEDEC standard J-STD-020)**

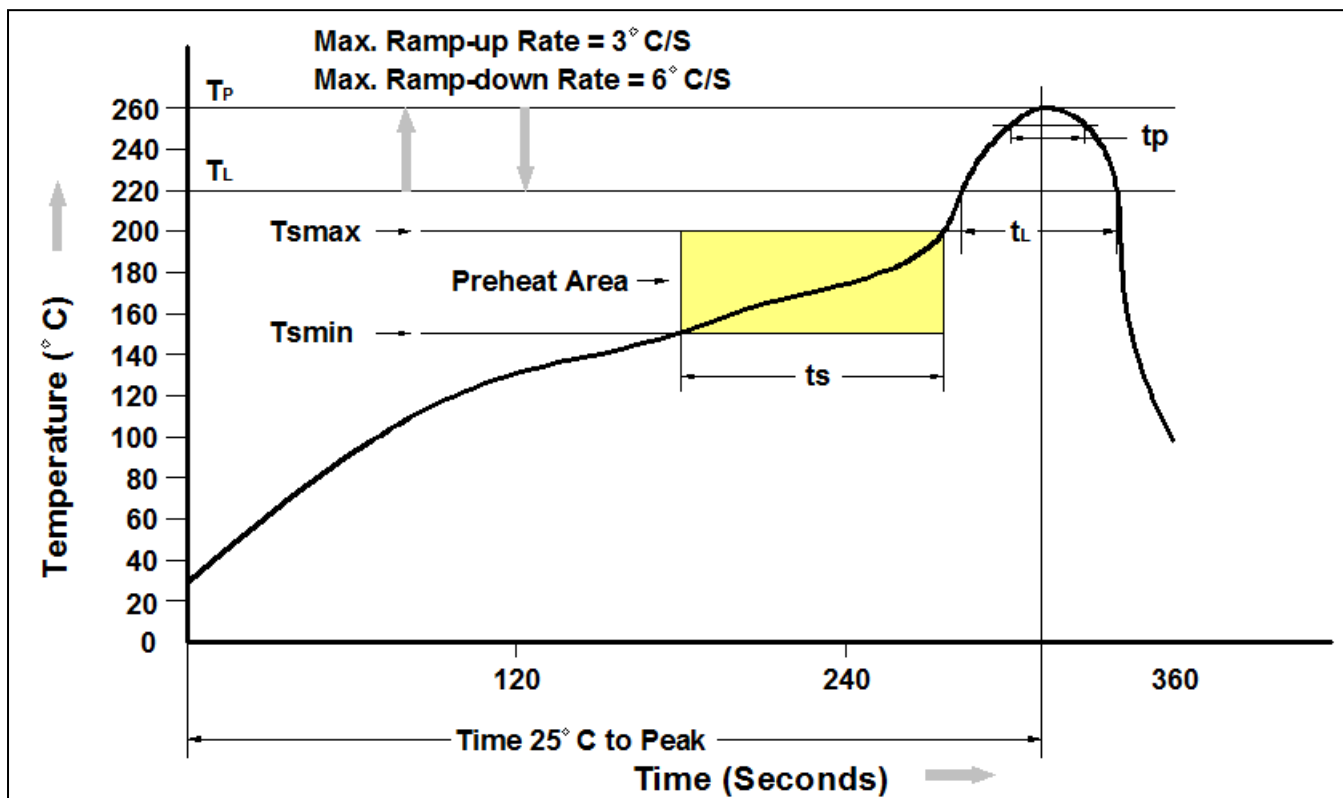

Profile Feature	Pb-Free Assembly Profile
Temperature Min. (T <sub>min</sub> )	150°C
Temperature Max. (T <sub>max</sub> )	200°C
Time (t <sub>s</sub> ) from (T <sub>min</sub> to T <sub>max</sub> )	60-120 seconds
Ramp-up Rate (t <sub>L</sub> to t <sub>P</sub> )	3°C/second max.
Liquidous Temperature (T <sub>L</sub> )	217°C
Time (t <sub>L</sub> ) Maintained Above (T <sub>L</sub> )	60 – 150 seconds
Peak Body Package Temperature	260°C +0°C / -5°C
Time (t <sub>P</sub> ) within 5°C of 260°C	30 seconds
Ramp-down Rate (T <sub>P</sub> to T <sub>L</sub> )	6°C/second max
Time 25°C to Peak Temperature	8 minutes max.



---

## DISCLAIMER

**DMC-Isolator® IS A TRADEMARK OF CT MICRO INTERNATIONAL CORPORATION AND/OR ITS SUBSIDIARIES. CT MICRO OWNS THE RIGHTS TO A NUMBER OF PATENTS, TRADEMARKS, COPYRIGHTS AND OTHER INTELLECTUAL PROPERTY.**

---

**CT MICRO RESERVES THE RIGHT TO MAKE CHANGES WITHOUT FURTHER NOTICE TO ANY PRODUCTS HEREIN TO IMPROVE RELIABILITY, FUNCTION OR DESIGN. CT MICRO DOES NOT ASSUME ANY LIABILITY ARISING OUT OF THE APPLICATION OR USE OF ANY PRODUCT OR CIRCUIT DESCRIBED HEREIN; NEITHER DOES IT CONVEY ANY LICENSE UNDER ITS PATENT RIGHTS, NOR THE RIGHTS OF OTHERS.**

---

**COLOUR CHANGE MIGHT OCCUR ON THE PACKAGE SURFACE AFTER SOLDERING, REFLOW OR LONG TERM USE. THIS DOES NOT IMPACT THE PRODUCT PERFORMANCE NOR THE PRODUCT RELIABILITY.**

---

**CT MICRO ARE NOT AUTHORIZED FOR USE AS CRITICAL COMPONENTS IN LIFE SUPPORT DEVICES OR SYSTEMS WITHOUT EXPRESS WRITTEN APPROVAL OF CT MICRO INTERNATIONAL CORPORATION.**

- 1. Life support devices or systems are devices or systems which, (a) are intended for surgical implant into the body, or (b) support or sustain life, or (c) whose failure to perform when properly used in accordance with instruction for use provided in the labelling, can be reasonably expected to result in significant injury to the user.*
- 2. A critical component is any component of a life support device or system whose failure to perform can be reasonably expected to cause the failure of the life support device or system, or to affect its safety or effectiveness*