



AC Input 16-Pin DMC-Isolator® Half Pitch Mini-Flat Phototransistor Optocoupler

www.ct-micro.com

Features

- High isolation 3750 V_{RMS}
- Patented coplanar structure DMC-Isolator®
- Various CTR selection available
- AC input with transistor output
- Operating temperature range - 55 °C to 110 °C
- External Creepage ≥ 5.0mm
- Distance Through Isolation ≥ 0.4mm
- Clearance Distance ≥ 5.0mm
- RoHS and REACH Compliance
- Halogen Free Compliance
- Regulatory Approvals
 - ✓ UL - UL1577 (E364000)
 - ✓ VDE - EN60747-5-5 (40039590)
 - ✓ CQC – GB4943.1, GB8898 (19001231772)
 - ✓ IEC62368 (FI/41119)

Description

The CTH244 series have four isolated channels, each channel contains a photo transistor optically coupled to an Infrared-emitting diode in a 16-lead DMC-Isolator® half pitch Mini-Flat package.

Applications

- AC-AC Converters
- Programmable controllers
- Telecommunication equipment
- Hybrid substrates that require high density mounting

Package Outline

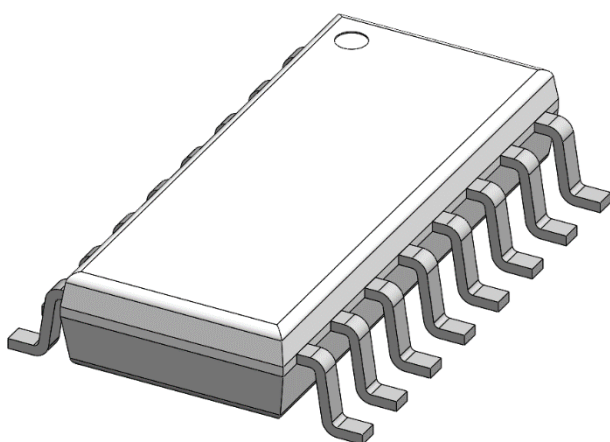

Schematic

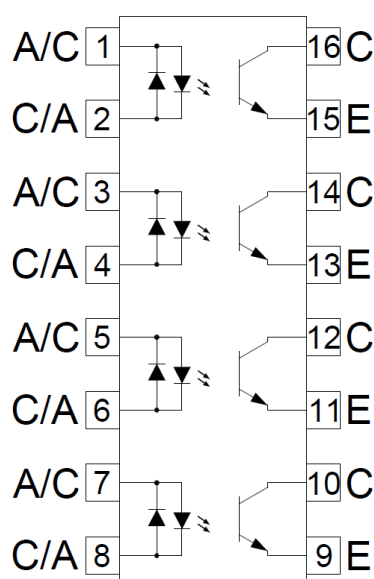



CTH244 Series

AC Input 16-Pin DMC-Isolator[®] Half Pitch Mini-Flat

Phototransistor Optocoupler

www.ct-micro.com

Absolute Maximum Ratings $T_A = 25^\circ\text{C}$, unless otherwise specified

Stresses in excess of the absolute maximum ratings can cause permanent damage to the device. Functional operation of the device is not implied at these or any other conditions in excess of those given in the operational sections of this document. In addition, extended exposure to stresses above the recommended operating conditions may affect device reliability. The absolute maximum ratings are stress ratings only.

Symbol	Parameters	Ratings	Units	Notes
V_{ISO}	Isolation voltage (AC, 1 minute, 40 ~ 60% R.H.)	3750	V_{RMS}	
T_{OPR}	Operating temperature	-55 ~ +110	$^\circ\text{C}$	
T_{STG}	Storage temperature	-55 ~ +150	$^\circ\text{C}$	
T_{SOL}	Soldering temperature	260	$^\circ\text{C}$	1
P_{TOT}	Total power dissipation	200	mW	
Emitter				
I_F	Forward current	± 50	mA	2
$I_{F(TRANS)}$	Peak transient current ($\leq 1\mu\text{s}$ P.W, 300pps)	1	A	2
P_D	Power dissipation	70	mW	2
Detector				
P_C	Power dissipation	100	mW	2
B_{VCEO}	Collector-Emitter Breakdown Voltage	80	V	2
B_{VECO}	Emitter-Collector Breakdown Voltage	7	V	2
I_C	Collector Current	50	mA	2

Note:

1. For reflow process
2. Each Channel



AC Input 16-Pin DMC-Isolator® Half Pitch Mini-Flat Phototransistor Optocoupler

www.ct-micro.com

Electrical Characteristics $T_A = 25^\circ\text{C}$, Each Channel (unless otherwise specified)

Emitter Characteristics

Symbol	Parameters	Test Conditions	Min	Typ	Max	Units	Notes
V_F	Forward voltage	$I_F = \pm 10\text{mA}$		1.24	1.4	V	
C_{IN}	Input Capacitance	$f = 1\text{MHz}$	-	10	30	pF	

Detector Characteristics

Symbol	Parameters	Test Conditions	Min	Typ	Max	Units	Notes
$B_{V_{CEO}}$	Collector-Emitter Breakdown	$I_C = 0.1\text{mA}$	80	-	-	V	
$B_{V_{ECO}}$	Emitter-Collector Breakdown	$I_E = 0.1\text{mA}$	7	-	-	V	
I_{CEO}	Collector-Emitter Dark Current	$V_{CE} = 20\text{V}$, $I_F = 0\text{mA}$	-	-	100	nA	

Transfer Characteristics

Symbol	Parameters	Test Conditions	Min	Typ	Max	Units	Notes
CTR	Current Transfer Ratio	CTH244	$I_F = \pm 1\text{mA}$, $V_{CE} = 5\text{V}$	20	-	300	%
		CTH244A		50	-	150	
		CTH244B		100	-	300	
	CTH244GB	$I_F = \pm 5\text{mA}$, $V_{CE} = 5\text{V}$	100		400	%	
	Symmetry	$I_F = \pm 1\text{mA}$, $V_{CE} = 5\text{V}$	0.5	-	2		
$V_{CE(SAT)}$	Collector-Emitter Saturation Voltage	$I_F = \pm 20\text{mA}$, $I_C = 1\text{mA}$	-	0.1	0.2	V	
R_{IO}	Isolation Resistance	$V_{IO} = 500\text{V}_{DC}$, 40 ~ 60% R.H.	5×10^{10}			Ω	
C_{IO}	Isolation Capacitance	$f = 1\text{MHz}$		0.5	1	pF	

Switching Characteristics

Symbol	Parameters	Test Conditions	Min	Typ	Max	Units	Notes
t_r	Rise Time	$I_C = 2\text{mA}$, $V_{CE} = 2\text{V}$, $R_L = 100\Omega$	-	6	18	μs	
t_f	Fall Time		-	8	18		



AC Input 16-Pin DMC-Isolator[®] Half Pitch Mini-Flat Phototransistor Optocoupler

Typical Characteristic Curves $T_A = 25^\circ\text{C}$, unless otherwise specified

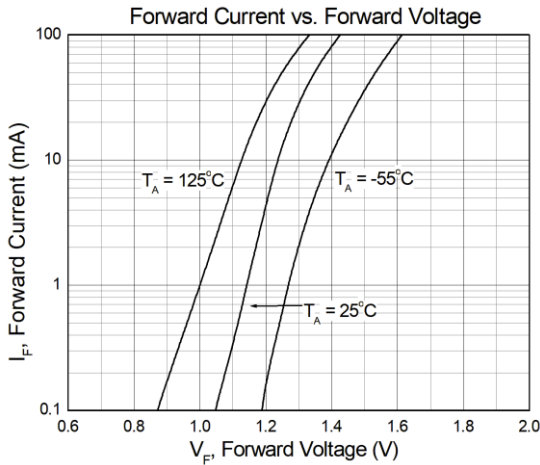

Figure 1

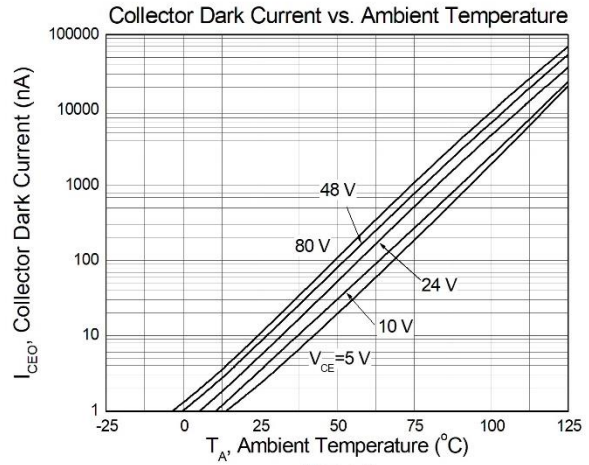

Figure 2

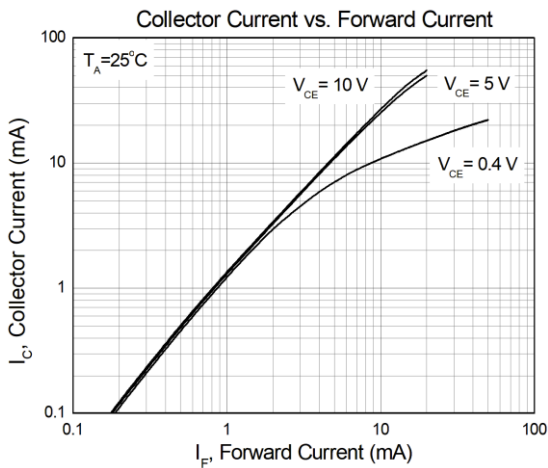

Figure 3

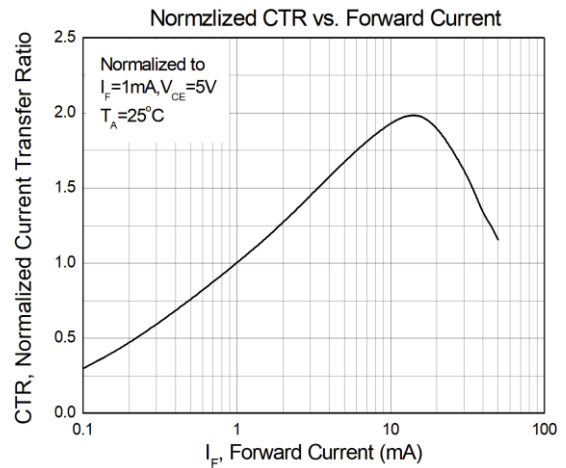

Figure 4

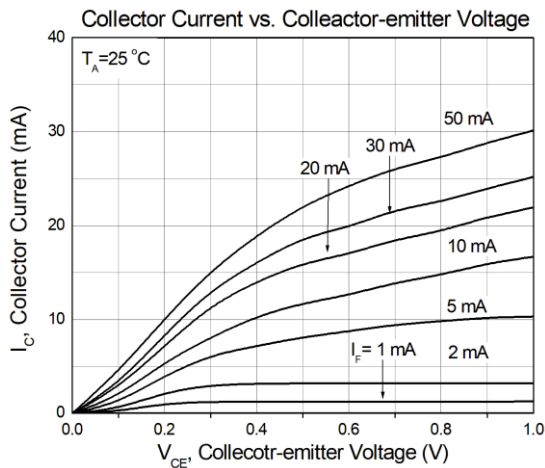

Figure 5

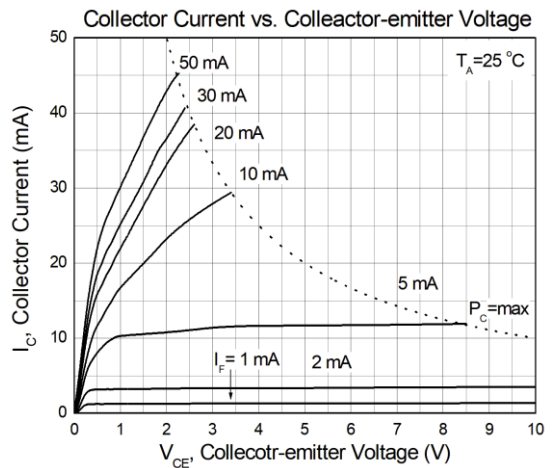

Figure 6



CTH244 Series

AC Input 16-Pin DMC-Isolator[®] Half Pitch Mini-Flat Phototransistor Optocoupler

www.ct-micro.com

Typical Characteristic Curves $T_A = 25^\circ\text{C}$, unless otherwise specified (Continued)

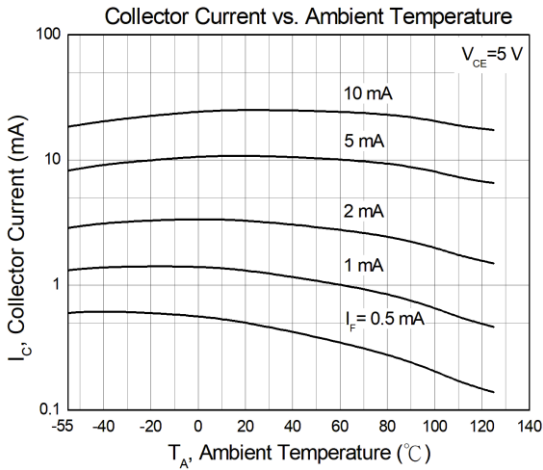

Figure 7

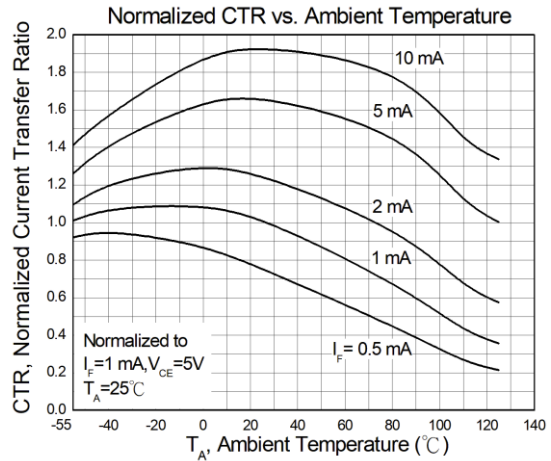

Figure 8

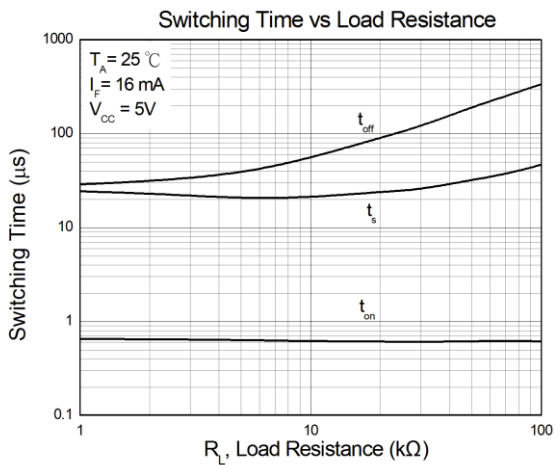

Figure 9

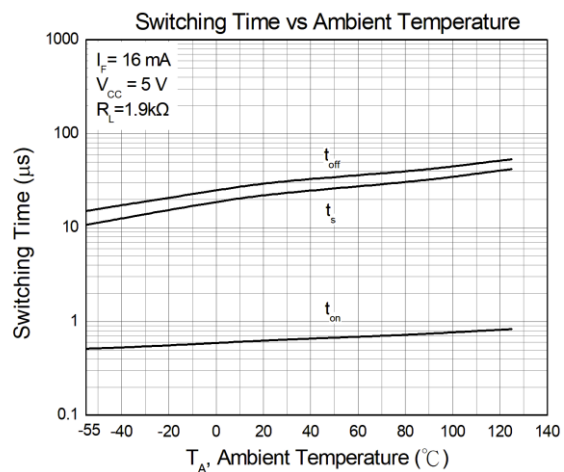

Figure 10

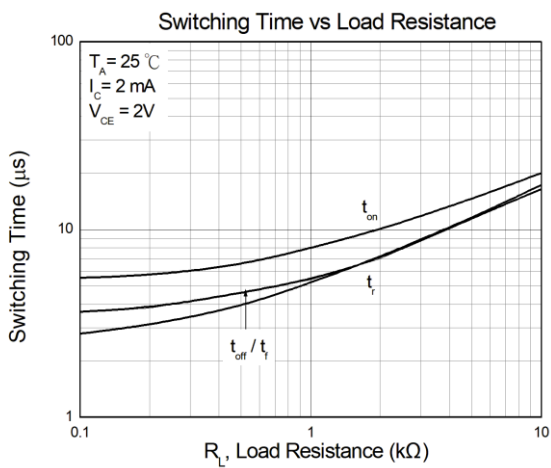

Figure 11

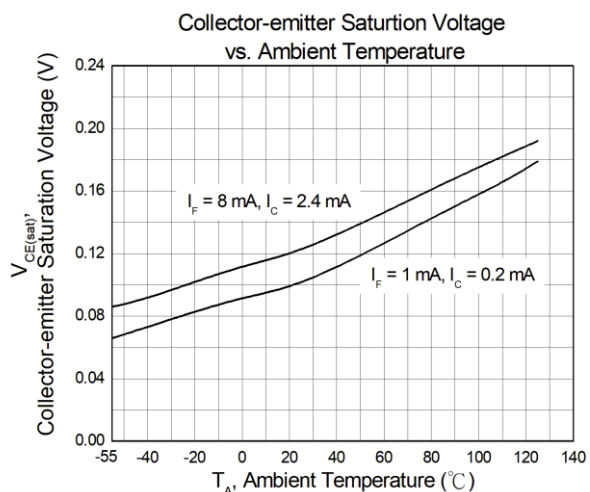

Figure 12



CTH244 Series AC Input 16-Pin DMC-Isolator[®] Half Pitch Mini-Flat Phototransistor Optocoupler

www.ct-micro.com

Test Circuit

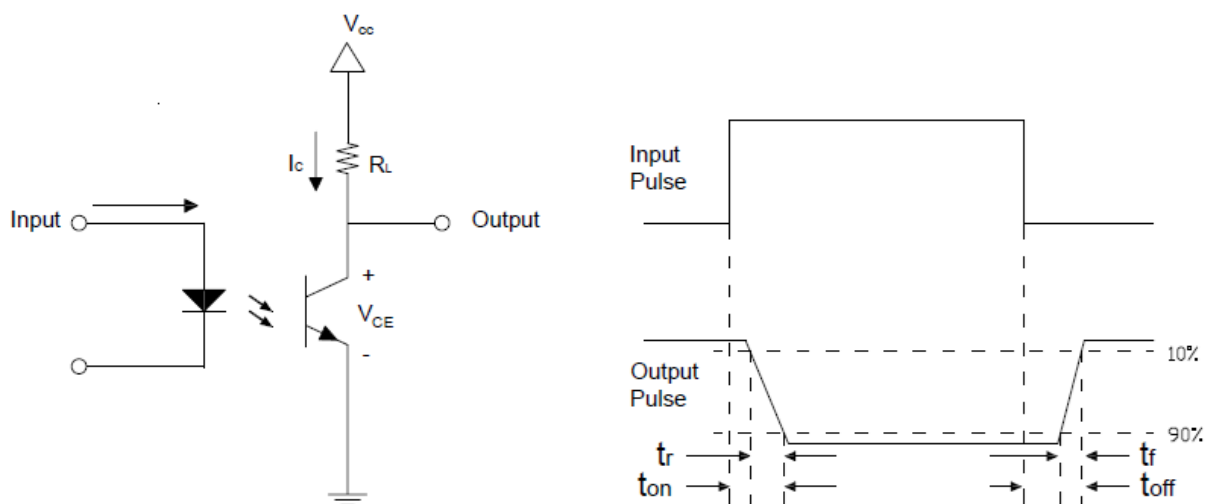

Figure13 : Switching Time Test Circuits



CTH244 Series

AC Input 16-Pin DMC-Isolator® Half Pitch Mini-Flat Phototransistor Optocoupler

www.ct-micro.com

Package Dimension *Dimensions in mm unless otherwise stated*

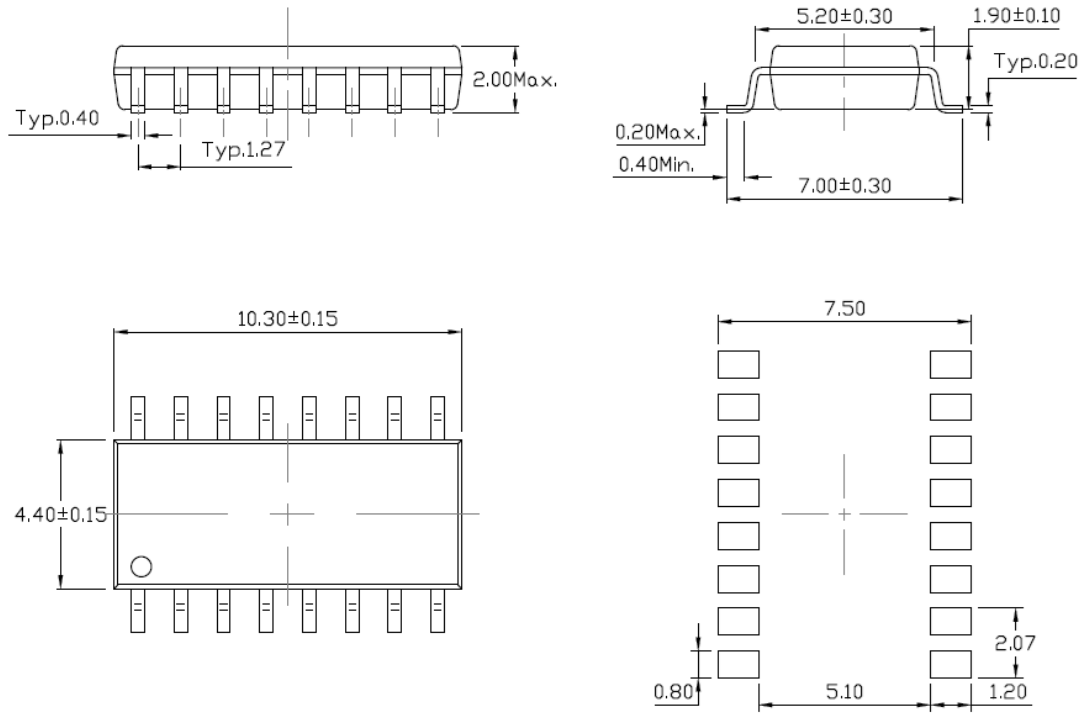

Marking Information

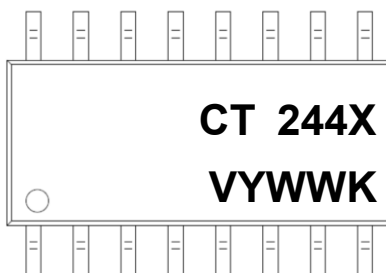

Note:

- CT : Denotes "CT Micro"
- 244 : Product Number
- X : CTR Rank
- V : VDE Safety Mark
- Y : One Digit Year Code
- WW : Two Digit Work Week
- K : Manufacturing Code



AC Input 16-Pin DMC-Isolator® Half Pitch Mini-Flat Phototransistor Optocoupler

www.ct-micro.com

Ordering Information

CTH244X(V)(Z)

- CT = Denotes "CT Micro"
- H244 = Product Number
- X = CTR Rank Option (Blank, A or GB)
- V = VDE Safety Mark Option (Blank or V)
- Z = Tape and Reel Option (T1 or T2)

Option	Description	Quantity
T1	Surface Mount Lead Forming – With Option 1 Taping	2000 Units/Reel
T2	Surface Mount Lead Forming – With Option 1 Taping	2000 Units/Reel

Reel Dimension *All dimensions are in mm, unless otherwise stated*

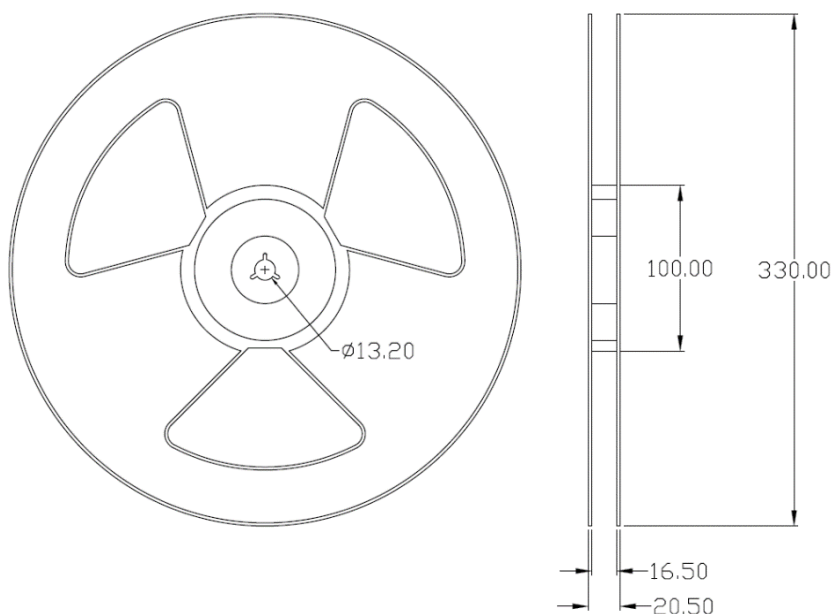



CTH244 Series AC Input 16-Pin DMC-Isolator® Half Pitch Mini-Flat Phototransistor Optocoupler

www.ct-micro.com

Carrier Tape Specifications *Dimensions in mm unless otherwise stated*

Option T1

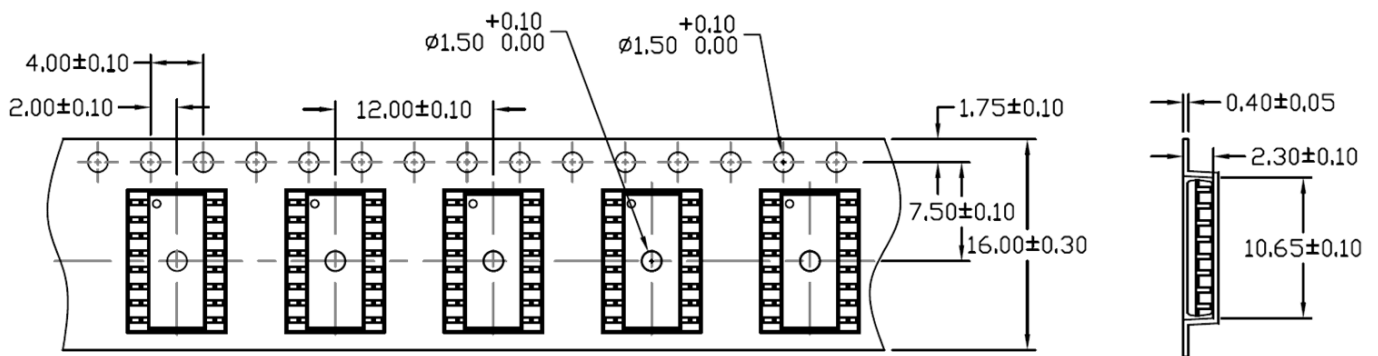

Option T2

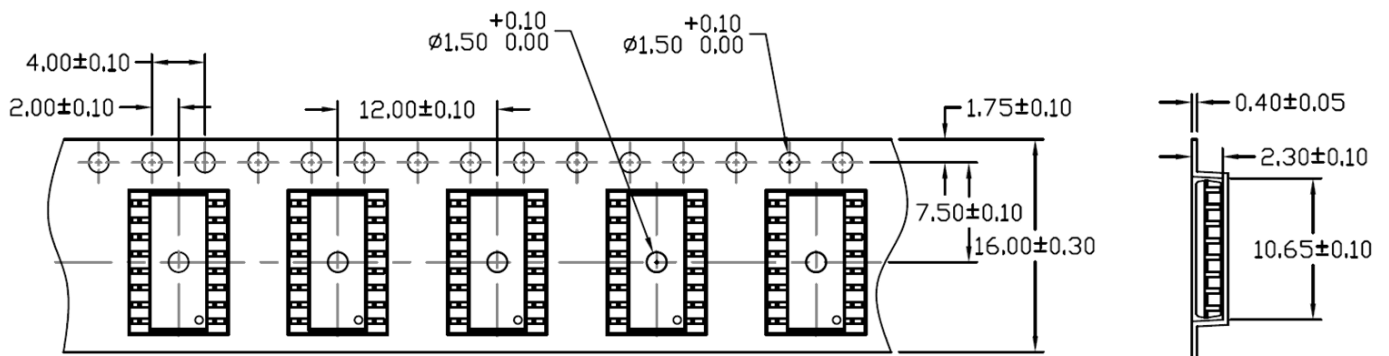



AC Input 16-Pin DMC-Isolator[®] Half Pitch Mini-Flat Phototransistor Optocoupler

www.ct-micro.com

Solderability spec (Follow the JEDEC standard JESD22-B102)

Reflow Soldering: Immersed surface, other than the end of pin as cut-surface, must be covered by solder.

Solder-Bath: More than 95% of the electrode must be covered with solder.

Wave soldering (Follow the JEDEC standard JESD22-A111)

One time soldering is recommended within the condition of temperature.

Temperature: $260 \pm 0/-5^\circ\text{C}$.

Time: 10 sec.

Preheat temperature: 25 to 140°C .

Preheat time: 30 to 80 sec.

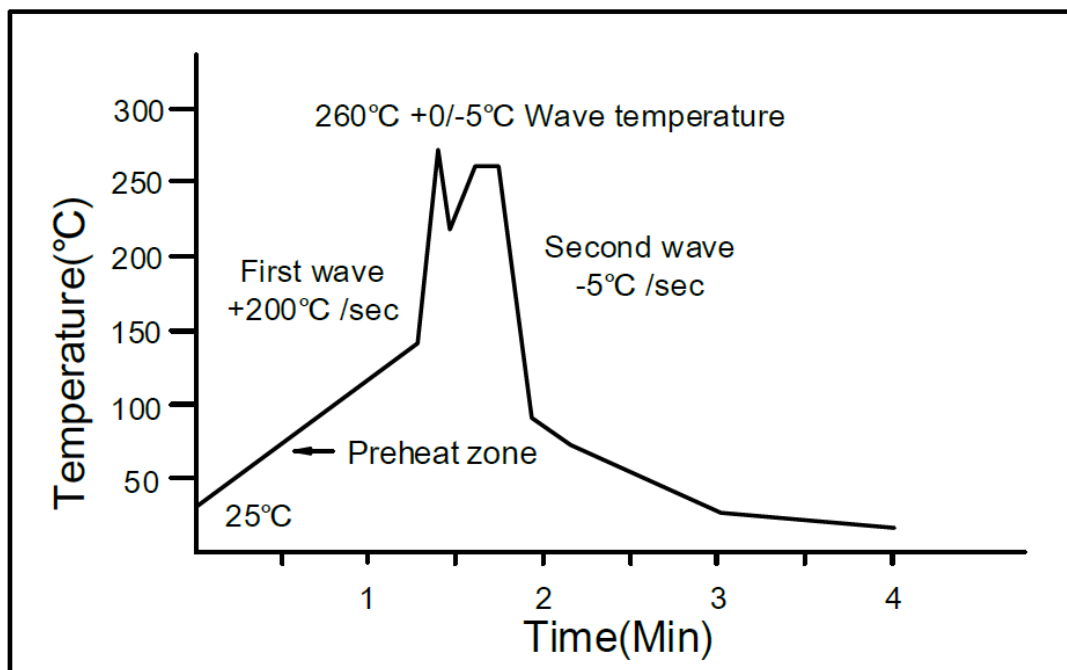

Iron soldering (Follow the standard MIL-STD 202G, Method 210F)

Allow single lead soldering in every single process.

One time soldering is recommended.

Temperature: $350 \pm 10^\circ\text{C}$

Time: 5 sec max.



CTH244 Series

AC Input 16-Pin DMC-Isolator[®] Half Pitch Mini-Flat Phototransistor Optocoupler

www.ct-micro.com

Reflow Profile (follow the JEDEC standard J-STD-020)

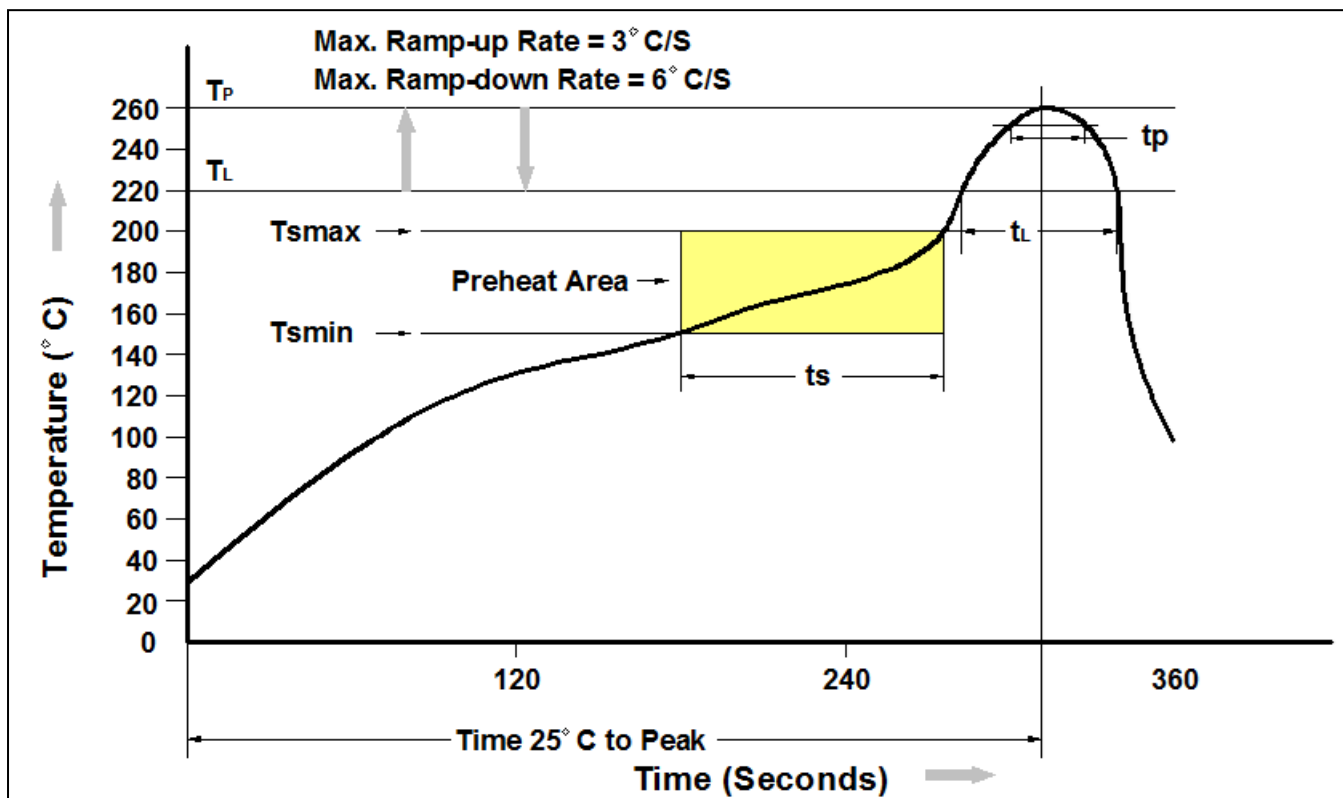

Profile Feature	Pb-Free Assembly Profile
Temperature Min. (T _{min})	150°C
Temperature Max. (T _{max})	200°C
Time (t _s) from (T _{min} to T _{max})	60-120 seconds
Ramp-up Rate (t _L to t _P)	3°C/second max.
Liquidous Temperature (T _L)	217°C
Time (t _L) Maintained Above (T _L)	60 – 150 seconds
Peak Body Package Temperature	260°C +0°C / -5°C
Time (t _P) within 5°C of 260°C	30 seconds
Ramp-down Rate (T _P to T _L)	6°C/second max
Time 25°C to Peak Temperature	8 minutes max.



CTH244 Series AC Input 16-Pin DMC-Isolator® Half Pitch Mini-Flat Phototransistor Optocoupler

DISCLAIMER

DMC-Isolator® IS A TRADEMARK OF CT MICRO INTERNATIONAL CORPORATION AND/OR ITS SUBSIDIARIES. CT MICRO OWNS THE RIGHTS TO A NUMBER OF PATENTS, TRADEMARKS, COPYRIGHTS AND OTHER INTELLECTUAL PROPERTY.

CT MICRO RESERVES THE RIGHT TO MAKE CHANGES WITHOUT FURTHER NOTICE TO ANY PRODUCTS HEREIN TO IMPROVE RELIABILITY, FUNCTION OR DESIGN. CT MICRO DOES NOT ASSUME ANY LIABILITY ARISING OUT OF THE APPLICATION OR USE OF ANY PRODUCT OR CIRCUIT DESCRIBED HEREIN; NEITHER DOES IT CONVEY ANY LICENSE UNDER ITS PATENT RIGHTS, NOR THE RIGHTS OF OTHERS.

DISCOLORATION MIGHT OCCUR ON THE PACKAGE SURFACE AFTER SOLDERING, REFLOW OR LONG TERM USE. THIS DOES NOT IMPACT THE PRODUCT PERFORMANCE NOR THE PRODUCT RELIABILITY.

CT MICRO ARE NOT AUTHORIZED FOR USE AS CRITICAL COMPONENTS IN LIFE SUPPORT DEVICES OR SYSTEMS WITHOUT EXPRESS WRITTEN APPROVAL OF CT MICRO INTERNATIONAL CORPORATION.

- 1. Life support devices or systems are devices or systems which, (a) are intended for surgical implant into the body, or (b) support or sustain life, or (c) whose failure to perform when properly used in accordance with instruction for use provided in the labelling, can be reasonably expected to result in significant injury to the user.*
- 2. A critical component is any component of a life support device or system whose failure to perform can be reasonably expected to cause the failure of the life support device or system, or to affect its safety or effectiveness*